



# PLAYA DEL SOL

PROJECT BRIEF





# PLAYA DEL SOL

## LIFE IN A DIFFERENT LIGHT

Welcome to Playa Del Sol, Ellington's exclusive development on the iconic shores of Al Marjan Island in Ras Al Khaimah. Playa Del Sol redefines island living, perfecting every detail for a lifestyle that feels uniquely yours. Embrace a vibrant way of life, where each moment is filled with beauty, serenity, and the rhythm of island living.



# A UNIQUE REFLECTION OF ISLAND LIFE



Playa Del Sol stands as a bold architectural statement, designed to immerse residents in stunning views of the Arabian Gulf while offering unparalleled proximity to the prestigious Wynn Resort.



# AN EMBODIMENT OF COASTAL ELEGANCE

AL JAZEERA  
AL HAMRA

HAYAT ISLAND

AL HAMRA  
VILLAGE

RAK CENTRAL

WYNN  
RESORT

ELLINGTON  
VIEWS

BEACH  
ACCESS

BEACH  
ACCESS

BEACH  
ACCESS

FISHING BOULEVARD

AL MARJAN ISLAND BOULEVARD

AL MARJAN ISLAND BOULEVARD





# DRIVING DISTANCES

- 04 MINS — WYNN RESORT
- 08 MINS — AL HAMRA MALL
- 09 MINS — RAK CENTRAL
- 10 MINS — AL HAMRA GOLF CLUB
- 12 MINS — ROYAL YACHT CLUB OF RAS AL KHAIMAH
- 12 MINS — RAK TRACK
- 25 MINS — RAK MALL
- 27 MINS — AL QAWASIM CORNICHE & RAK EYE
- 31 MINS — RAK INTERNATIONAL AIRPORT
- 33 MINS — RAK ECONOMIC ZONE
- 42 MINS — JEBEL JAIS ENTRANCE
- 45 MINS — SHARJAH INTERNATIONAL AIRPORT
- 60 MINS — DUBAI INTERNATIONAL AIRPORT

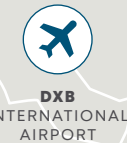
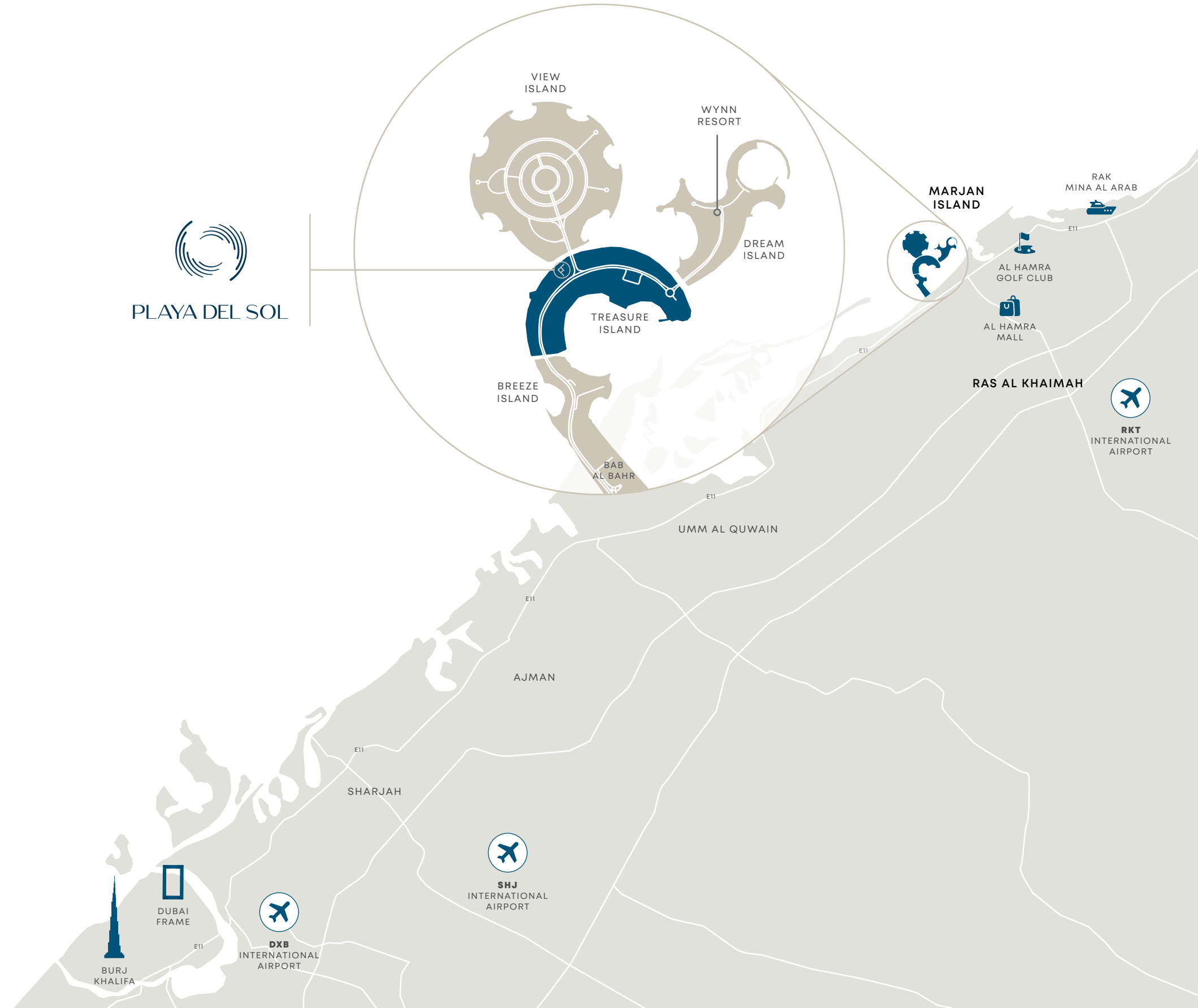



# SUN & VIEWS ANALYSIS

SUNSET



PLAYA DEL SOL



SUMMER

WINTER



SUNRISE





AN UNPARALLELED  
ISLAND LIVING





# ARCHITECTURAL CONCEPT

01

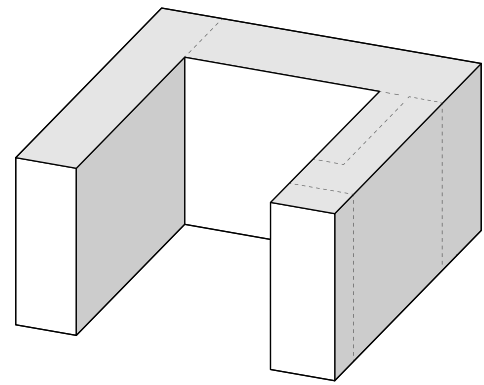

02

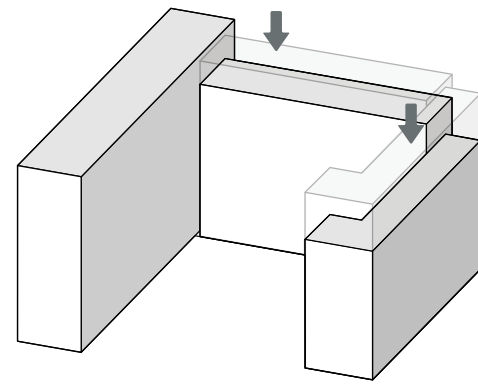

03

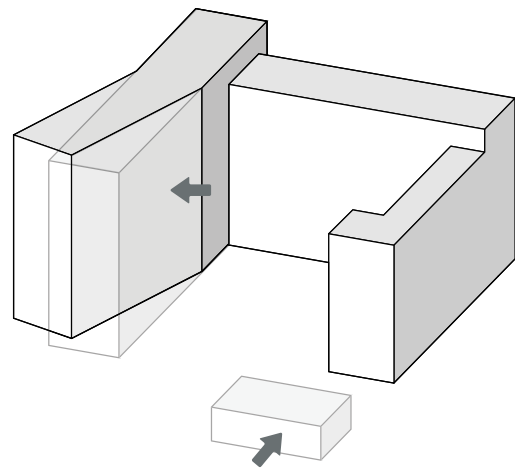

04

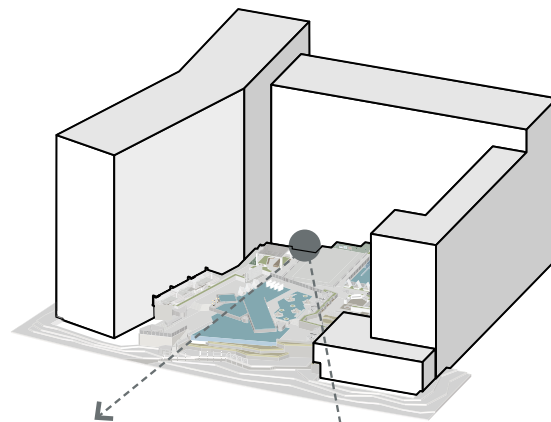

Maximising key views,  
value to apartments and  
public space orientation  
to the site and context.

05



A retreat where wellness, fitness, and  
social indulgence come together in  
perfect harmony.







# BUILDING CONFIGURATION



2B + GF + 14R



# BREATHTAKING HORIZONS

## 360 VIEWS

Wynn Resort, Arabian Gulf,  
Al Marjan Island

## ANTICIPATED COMPLETION DATE

Q4 2027

## OWNERSHIP

Freehold

## ANTICIPATED SERVICE CHARGE

AED 16 per sq.ft.

## ELEVATORS

6 passenger elevators  
2 service elevators

## PARKING

Studio, 1 and 2 beds: 1 parking  
3-bed: 2 car parking  
4-bed penthouses: 3 car parking  
5-bed villa: 4 car parking





# UNIT SIZES AND TYPES



## APARTMENTS

## NUMBER OF UNITS

## SIZE RANGE

STUDIOS

34 units

From 400.85 sq. ft.

1-BEDROOM APARTMENTS

274 units

From 683.62 sq. ft. to 758.86 sq. ft.

2-BEDROOM APARTMENTS

185 units

From 1,061.86 sq. ft. to 1,381.76 sq. ft.

3-BEDROOM APARTMENTS

20 units

From 1,898.00 sq. ft. to 3,778.56 sq. ft.

4-BEDROOM PENTHOUSE

2 units

From 3,459.09 sq. ft. to 3,550.37 sq. ft.

5-BEDROOM VILLA

1 unit

From 8,524.69 sq. ft.

---

**516** TOTAL RESIDENTIAL UNITS





# AMENITIES

An oasis of timeless coastal elegance, Playa Del Sol is a sanctuary designed for a balanced lifestyle of relaxation and recreation. Offering a curated experience, Playa Del Sol seamlessly merges waterfront living with world-class leisure.



# AMENITIES SECTIONING

## 1<sup>ST</sup> FLOOR

Clubhouse  
Kids Club  
Gym  
Yoga Studio  
Changing Room + Sauna

## GROUND FLOOR

Main Lobby  
Wellness Spa  
Squash Courts

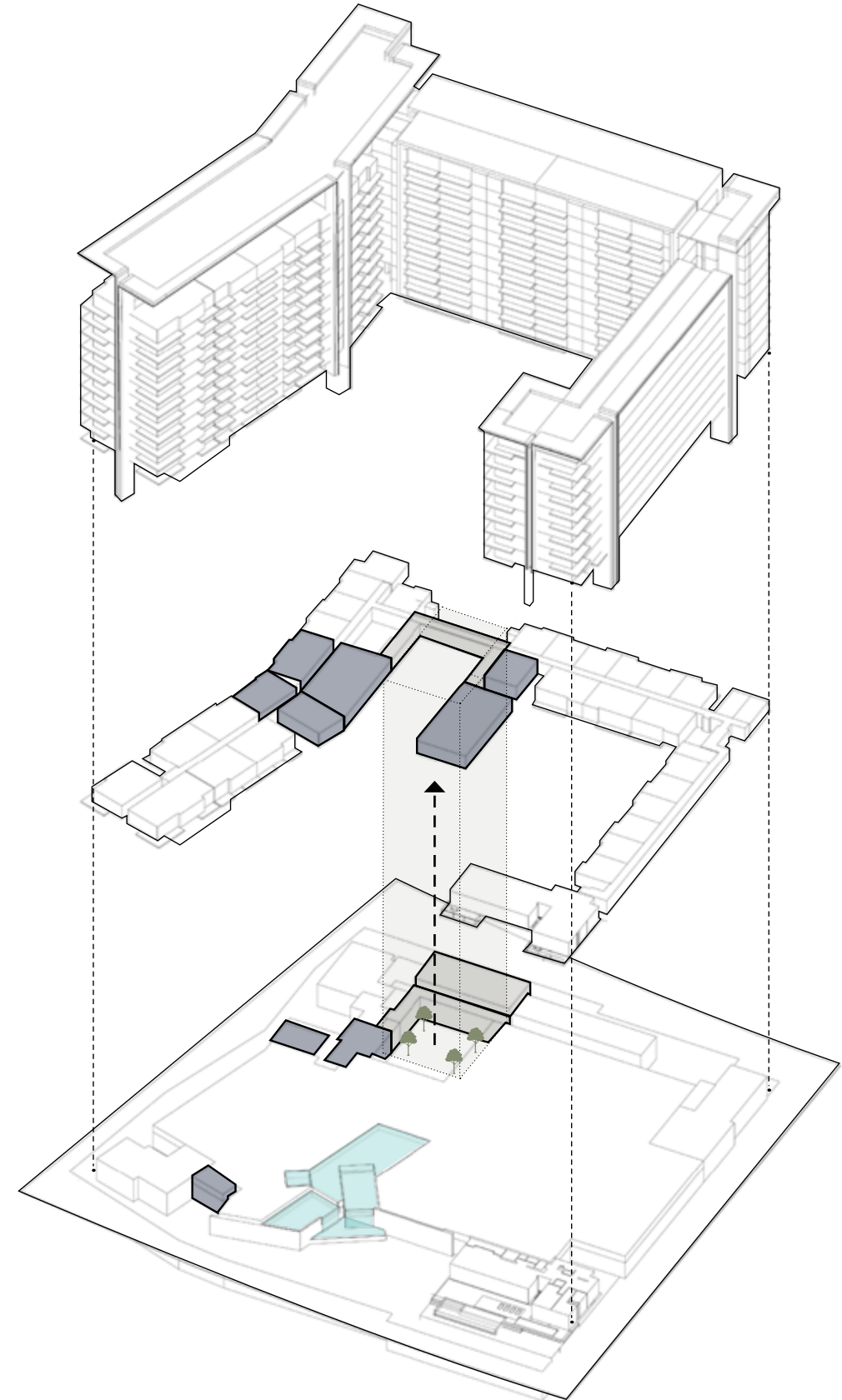





GROUND FLOOR AMENITIES



# GROUND FLOOR AMENITIES PLAN

- 1 MAIN ENTRANCE/EXIT
- 2 DROP-OFF AREA
- 3 ENTRYWAY SEATING
- 4 BICYCLE PARKING
- 5 LOBBY ENTRANCE
- 6 LOBBY RECEPTION
- 7 LOBBY LOUNGE
- 8 OUTDOOR LOUNGE
- 9 SUNKEN GARDEN
- 10 SPA TERRACE
- 11 SALON AREA
- 12 SPA TREATMENT ROOM
- 13 SQUASH COURT
- 14 LIFT LOBBY
- 15 SERVICE LIFT
- 16 MOVE-IN TRUCK ZONE
- 17 EV CHARGING STATION
- 18 ACCESS TO RESIDENTS PARKING
- 19 VILLA PRIVATE ENTRANCE
- 20 ACCESS TO UPPER POOL DECK
- 21 LOWER DECK SUN LOUNGERS AREA
- 22 CASCADE WATERFALL
- 23 GARDEN BENCHES
- 24 CHANGE ROOMS
- 25 ACCESS TO BOARDWALK
- 26 ACCESS TO PRIVATE JETTY
- 27 FIRST CLASS YACHT SERVICE



GROUND FLOOR







  
PLAYA DEL SOL



☾ DROP-OFF AREA AND LOBBY ENTRANCE ☽





LOBBY RECEPTION





LOBBY LOUNGE





SUNKEN GARDEN





SALON & SPA TREATMENT ROOMS





SQUASH COURT





PLAYA DEL SOL JETTY AND  
AL MARJAN ISLAND BOARDWALK



1<sup>ST</sup> FLOOR AMENITIES





# 1<sup>ST</sup> FLOOR AMENITIES PLAN

- 1 ADULT POOL OASIS
- 2 BAJA SHELF
- 3 POOL SPA
- 4 WATER LOUNGE
- 5 SUN LOUNGERS AREA
- 6 CABANAS
- 7 OUTDOOR SHOWER
- 8 POOL DECK ACCESS
- 9 LOUNGE PLAZA
- 10 CLUBHOUSE TERRACE
- 11 CLUBHOUSE
- 12 PANTRY
- 13 TEENS CLUBHOUSE
- 14 OUTDOOR KIDS PLAY AREA
- 15 INDOOR KIDS PLAY AREA
- 16 KIDS POOL
- 17 OUTDOOR FITNESS AREA
- 18 GARDEN TERRACE & LOUNGE
- 19 GAMES TABLE ZONE
- 20 BARBEQUE DECK WITH DINING & SEATING
- 21 ACCESS TO BOARDWALK
- 22 OUTDOOR YOGA AREA
- 23 YOGA STUDIO
- 24 FITNESS STUDIO
- 25 FEMALE CHANGE ROOM
- 26 MALE CHANGE ROOM
- 27 LIFT LOBBY







ADULT OASIS POOL





CLUBHOUSE





TEENS CLUBHOUSE





FITNESS STUDIO





YOGA STUDIO





KIDS PLAY AREA



## THE RESIDENCES

Playa Del Sol embodies the tranquil beauty and dynamic spirit of its coastal environment. The residences embrace natural materials, carefully chosen to reflect the luminous qualities of sunrises and sunsets unique to this setting. The interiors prioritize a seamless connection with nature, showcasing refined craftsmanship and elegant transitions that perfectly balance aesthetics with practicality.







BALCONY VIEW





LIVING AND DINING AREA





KITCHEN





BEDROOM





BATHROOM





POWDER ROOM



## SIGNATURE RESIDENCES

The signature residences at Playa Del Sol offer an unparalleled living experience, featuring penthouses, duplex apartments, and a villa that command breathtaking views of the sea. With unobstructed vantage points to the ever-changing seascape, these residences create the perfect sanctuary, where elegance seamlessly blends with the tranquility of the ocean.



# VILLA DESIGN

5-BEDROOM VILLA (B + G + 1)



FIRST FLOOR

GROUND FLOOR

BASEMENT

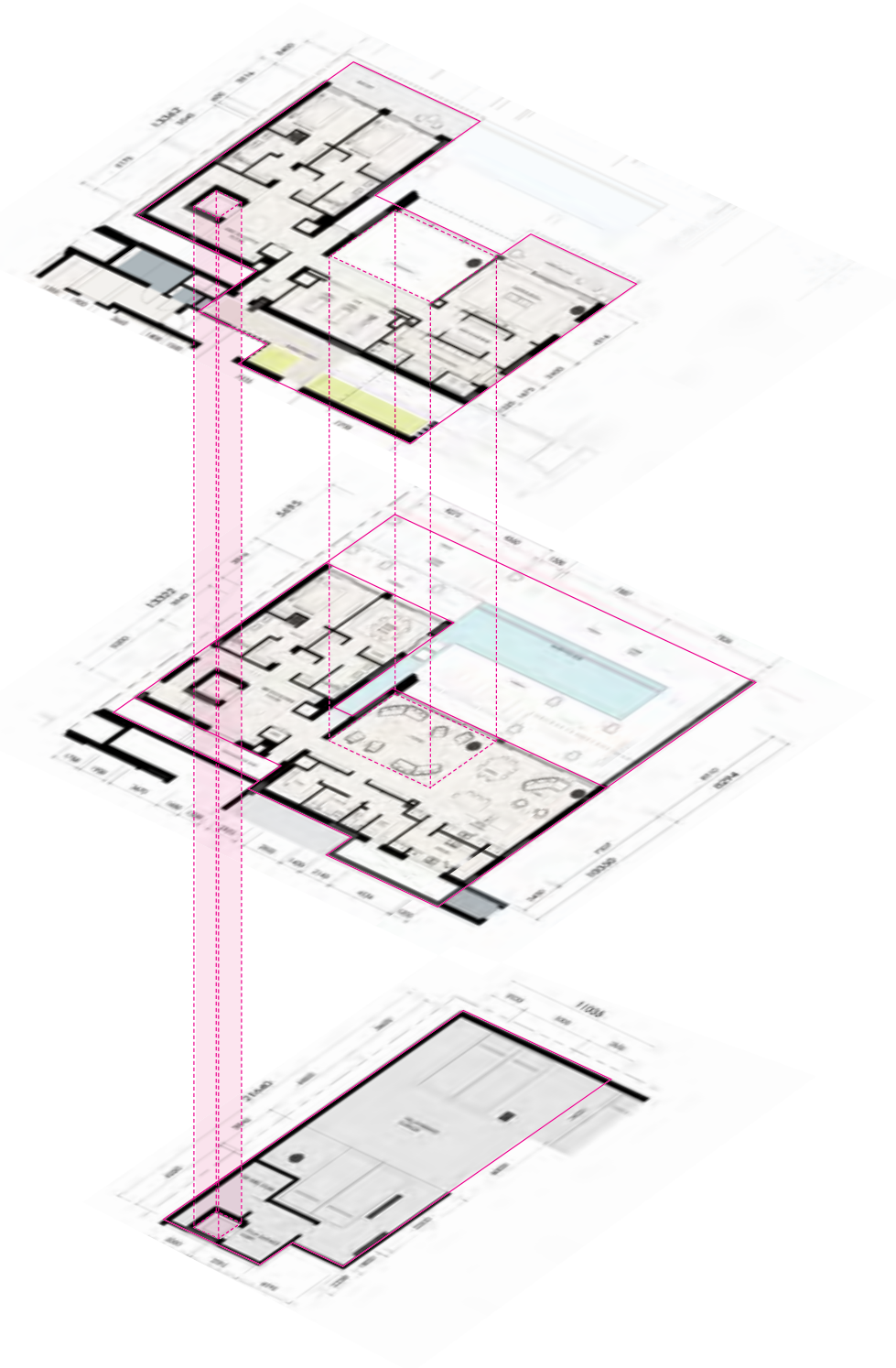



# DUPLEX APARTMENTS



FIRST FLOOR

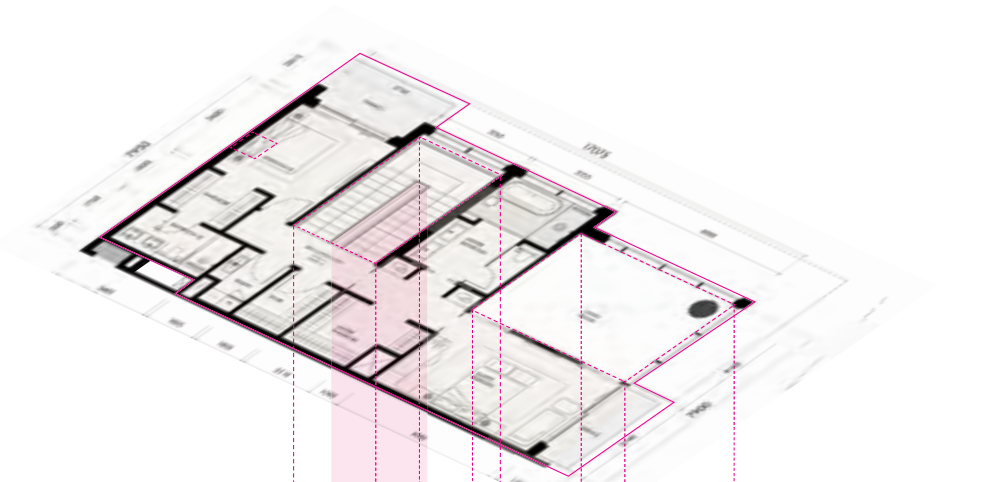

GROUND FLOOR

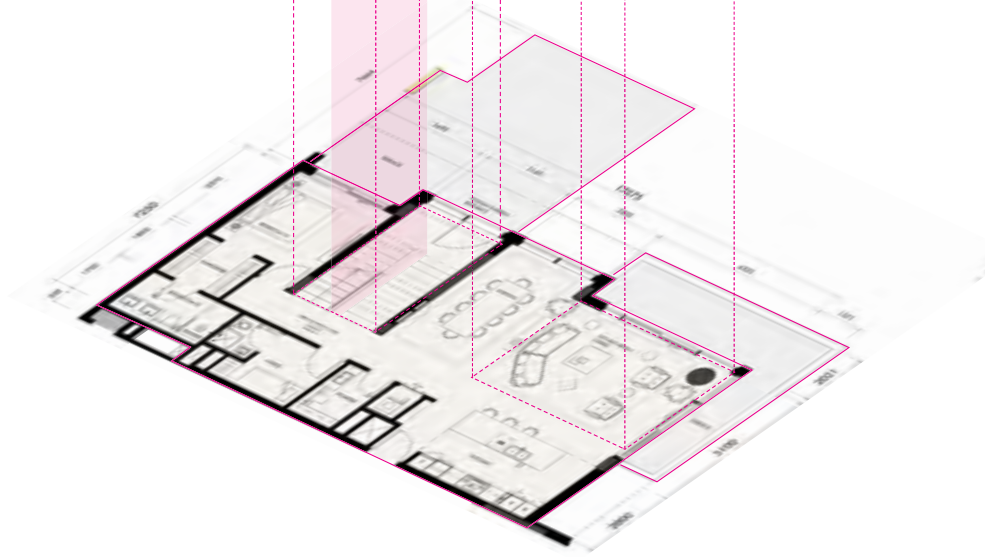



# PENTHOUSES

4-BEDROOM



10<sup>TH</sup> FLOOR  
TYPE A

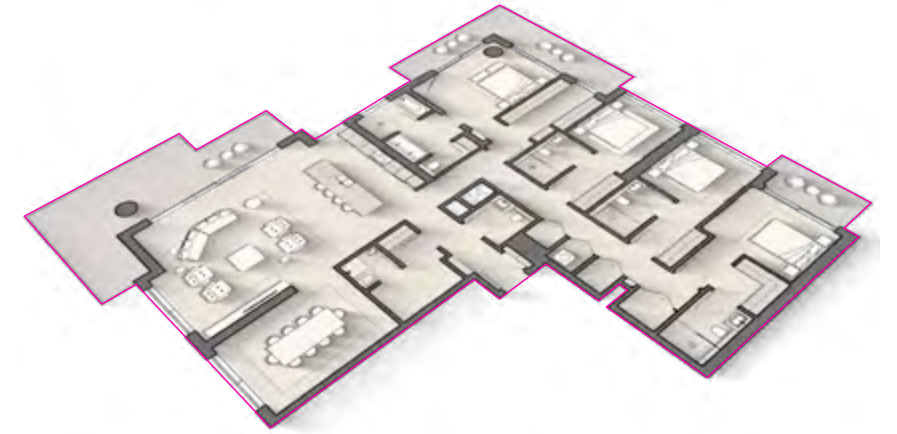

14<sup>TH</sup> FLOOR  
TYPE B

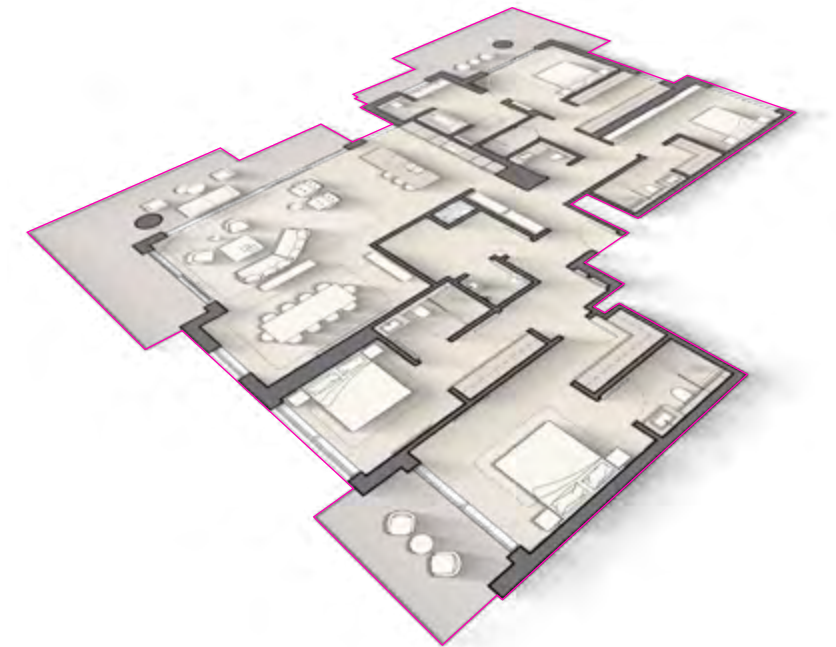



ELLINGTON

SIGNATURE VILLA WITH  
A PRIVATE POOL AND GARDEN







VILLA ENTRANCE



# FLOOR PLANS





# GROUND FLOOR TYPICAL PLAN

VILLA  
(UPPER LEVEL)



GROUND FLOOR



# 1<sup>ST</sup> FLOOR TYPICAL PLAN

-  STUDIO
-  1-BEDROOM
-  2-BEDROOM
-  3-BEDROOM DUPLEX  
(LOWER LEVEL)
-  VILLA  
(UPPER LEVEL)

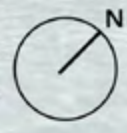



# 2<sup>ND</sup> FLOOR TYPICAL PLAN

-  STUDIO
-  1-BEDROOM
-  2-BEDROOM
-  3-BEDROOM
-  3-BEDROOM DUPLEX  
(UPPER LEVEL)





# 3<sup>RD</sup> - 9<sup>TH</sup> FLOOR TYPICAL PLAN

- STUDIO
- 1-BEDROOM
- 2-BEDROOM
- 3-BEDROOM



— 3RD & 9TH FLOOR



# 10<sup>TH</sup> FLOOR TYPICAL PLAN

- STUDIO
- 1-BEDROOM
- 2-BEDROOM
- 3-BEDROOM
- 4-BEDROOM PENTHOUSE





# 11<sup>TH</sup> - 12<sup>TH</sup> FLOOR TYPICAL PLAN

-  STUDIO
-  1-BEDROOM
-  2-BEDROOM
-  3-BEDROOM



11TH & 12TH FLOOR



# 13<sup>TH</sup> FLOOR TYPICAL PLAN

- 1-BEDROOM
- 2-BEDROOM
- 3-BEDROOM





# 14<sup>TH</sup> FLOOR TYPICAL PLAN

- 1-BEDROOM
- 2-BEDROOM
- 4-BEDROOM PENTHOUSE





# STUDIO

## TYPE A

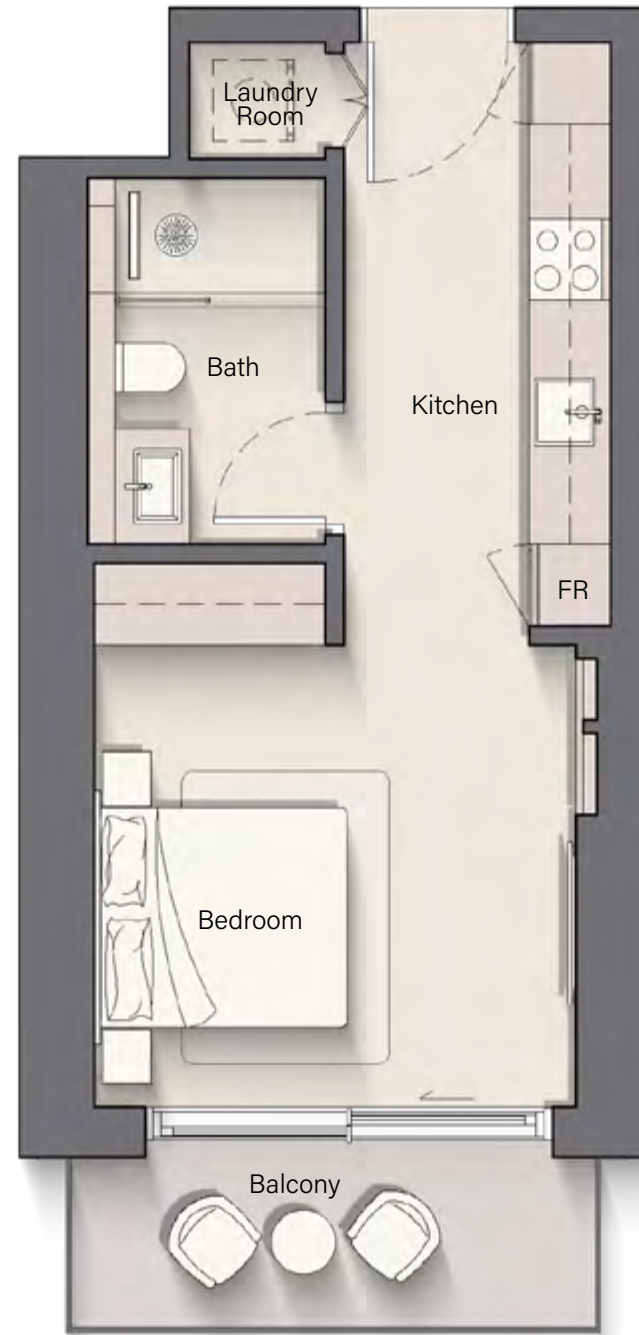

INTERNAL LIVING AREA	339.82 SQ. FT
OUTDOOR LIVING AREA	70.72 SQ. FT
<b>TOTAL LIVING AREA</b>	<b>410.54 SQ. FT</b>

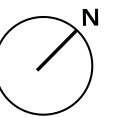
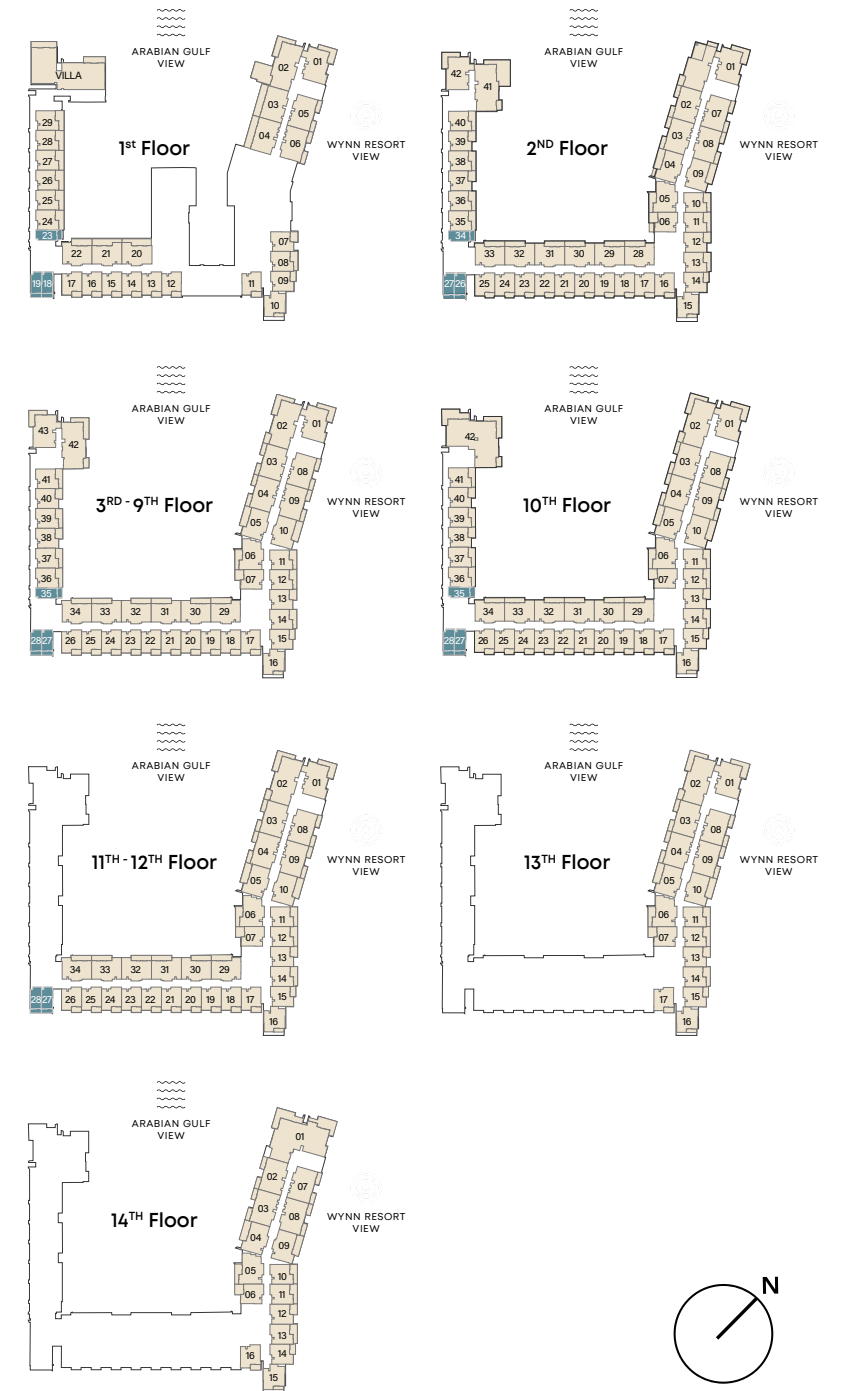



# 1-BEDROOM

TYPE A



INTERNAL LIVING AREA	614.73 SQ. FT
OUTDOOR LIVING AREA	87.94 SQ. FT
<b>TOTAL LIVING AREA</b>	<b>702.67 SQ. FT</b>

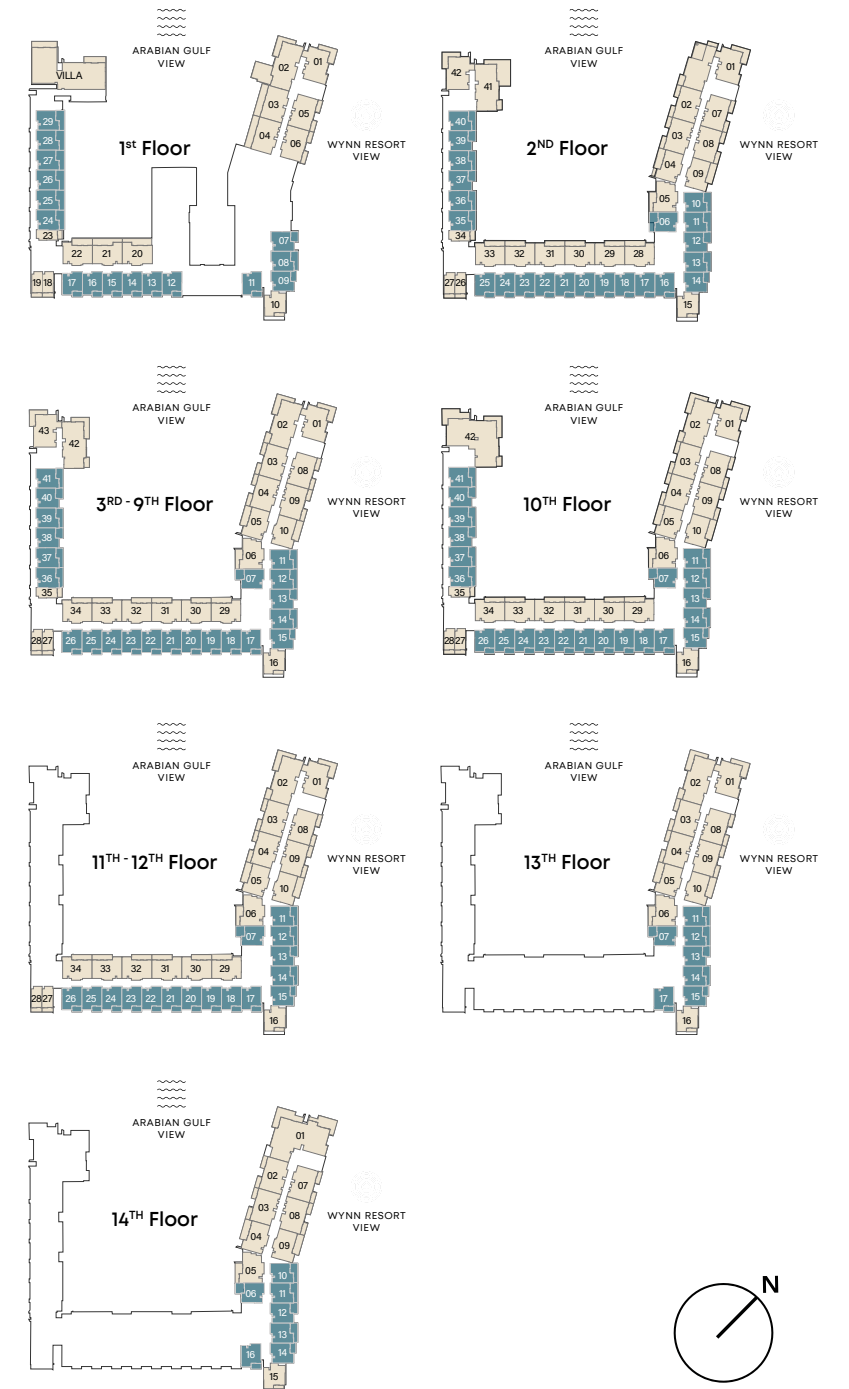



# 1-BEDROOM

TYPE B



INTERNAL LIVING AREA	688.24 SQ. FT
OUTDOOR LIVING AREA	70.61 SQ. FT
<b>TOTAL LIVING AREA</b>	<b>758.86 SQ. FT</b>

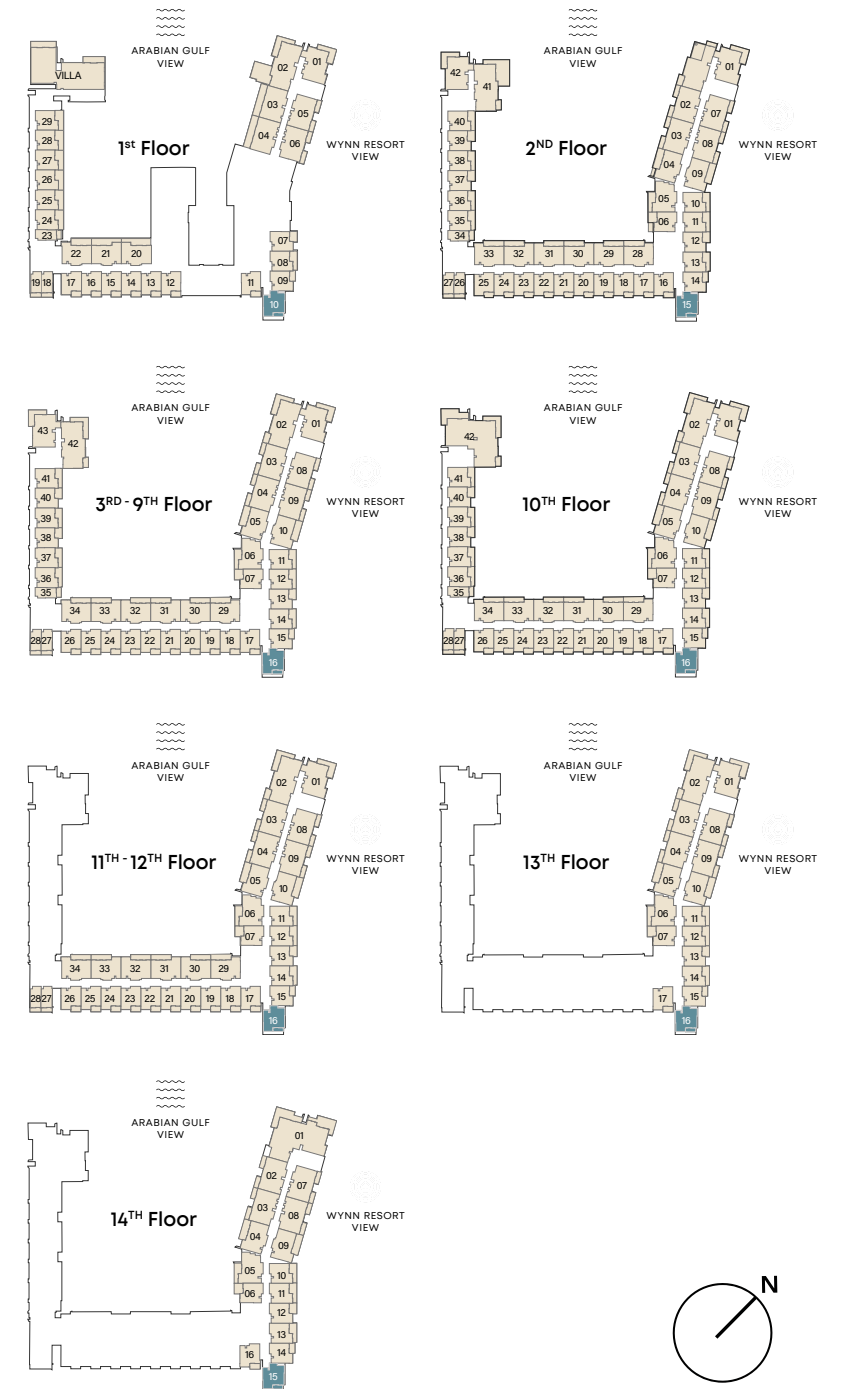



# 1-BEDROOM

TYPE B



INTERNAL LIVING AREA	688.24 SQ. FT
OUTDOOR LIVING AREA	70.61 SQ. FT
<b>TOTAL LIVING AREA</b>	<b>758.86 SQ. FT</b>

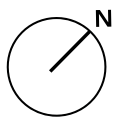
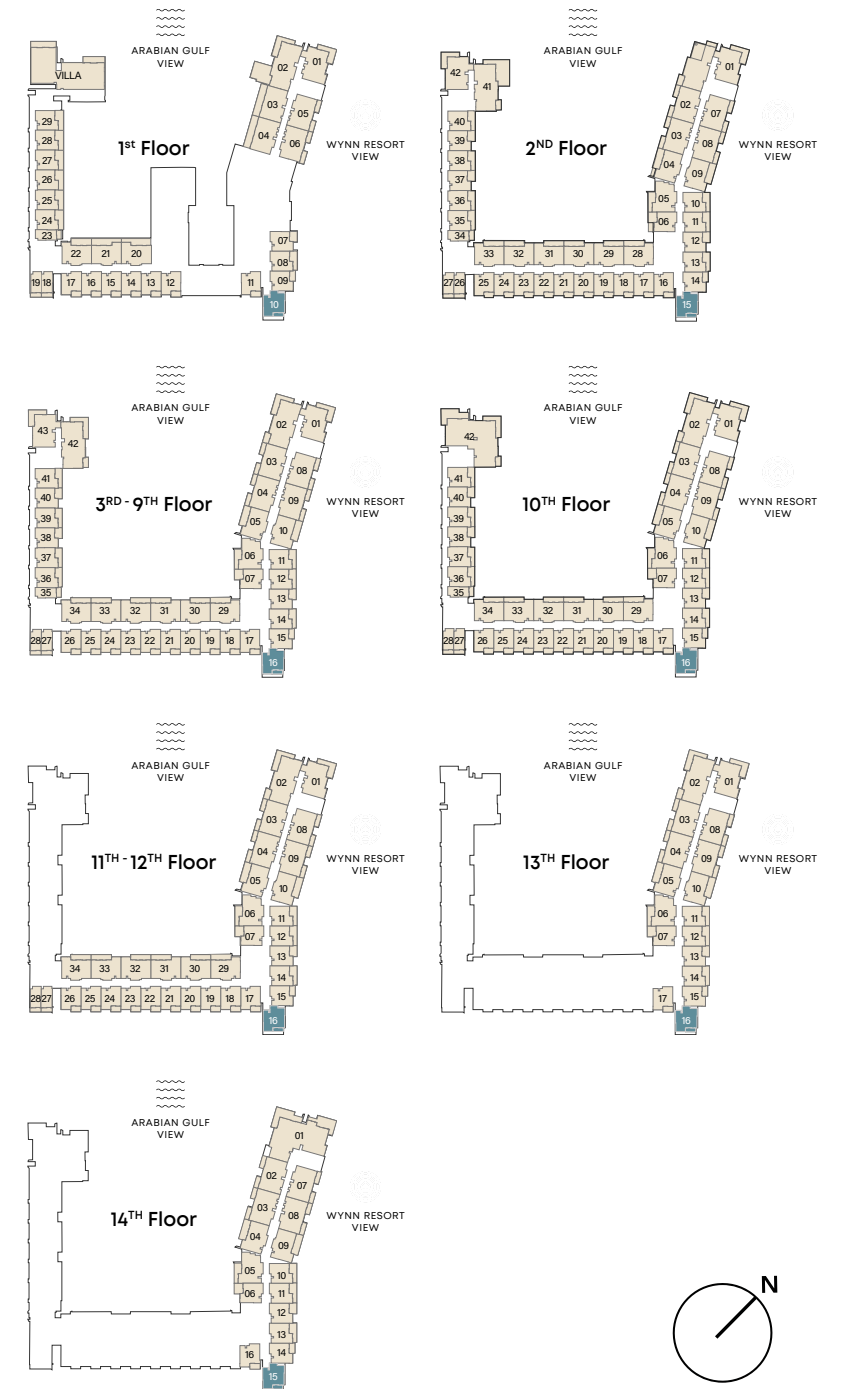



# 2-BEDROOM

## TYPE A



INTERNAL LIVING AREA	905.68 SQ. FT
OUTDOOR LIVING AREA	168.24 SQ. FT
<b>TOTAL LIVING AREA</b>	<b>1073.92 SQ. FT</b>

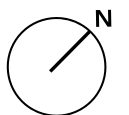
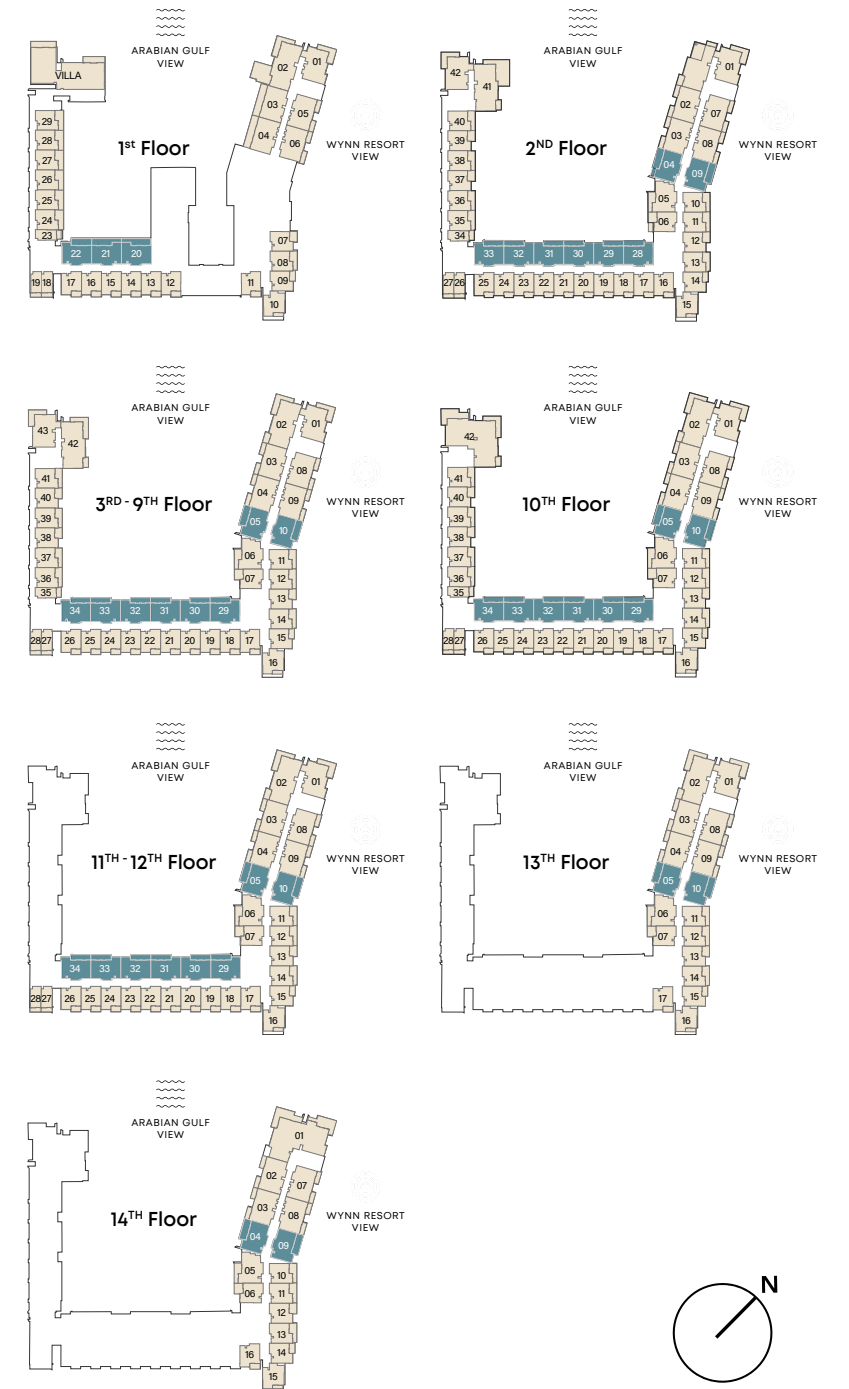



# 2-BEDROOM

TYPE B



INTERNAL LIVING AREA	939.47 SQ. FT
OUTDOOR LIVING AREA	180.73 SQ. FT
<b>TOTAL LIVING AREA</b>	<b>1120.20 SQ. FT</b>

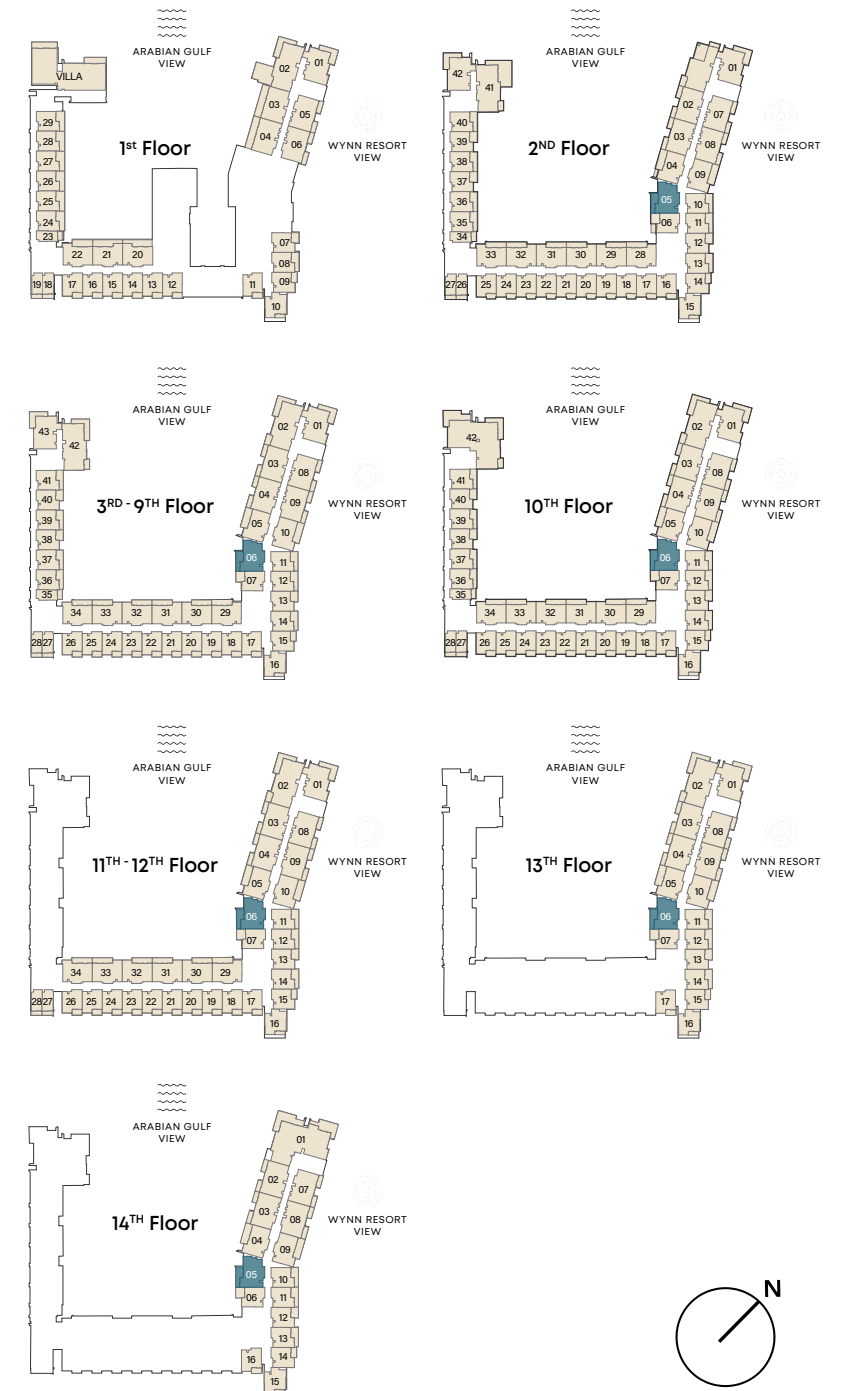



# 2-BEDROOM

TYPE C



INTERNAL LIVING AREA	1083.28 SQ. FT
OUTDOOR LIVING AREA	167.27 SQ. FT
<b>TOTAL LIVING AREA</b>	<b>1250.55 SQ. FT</b>

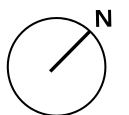
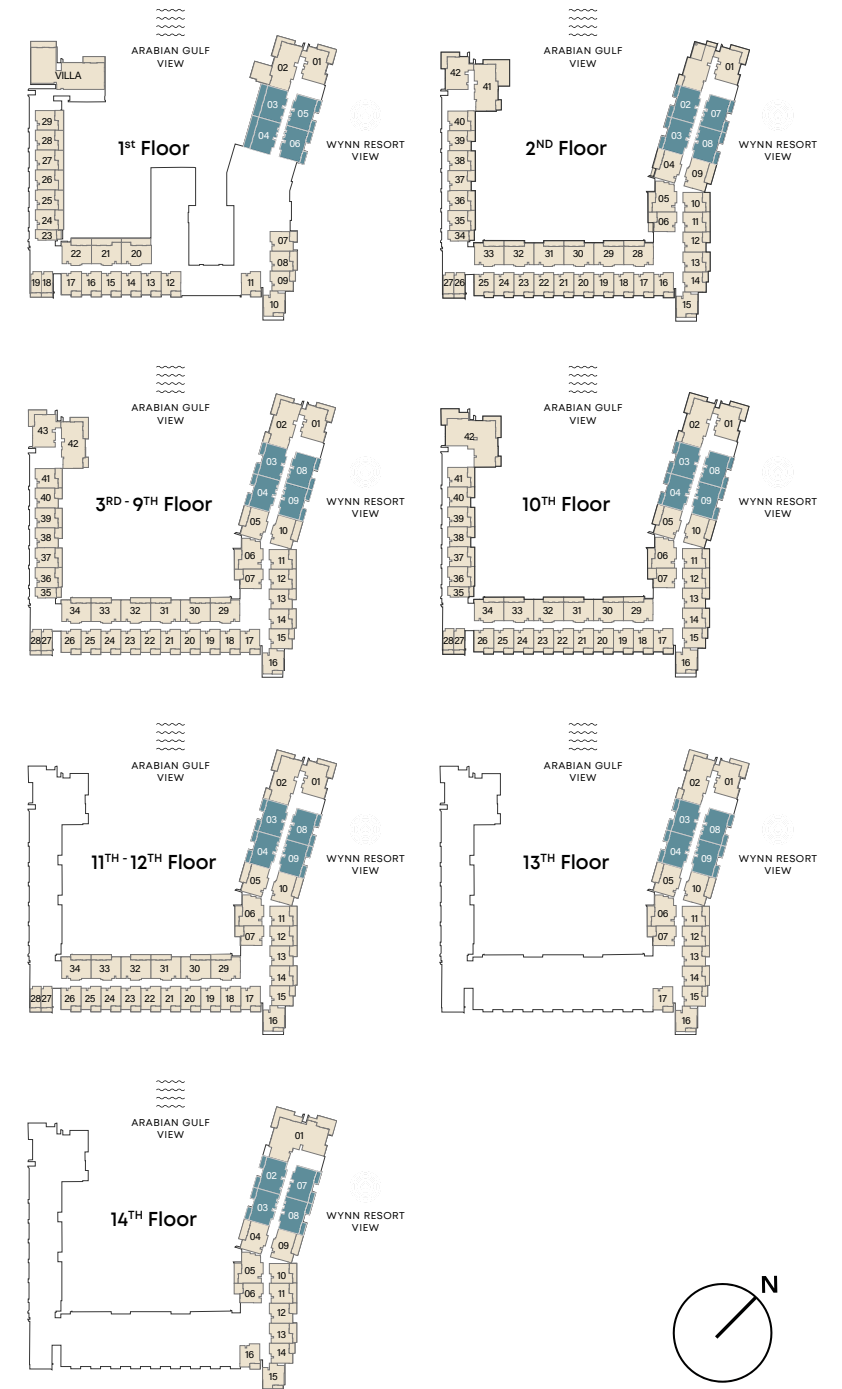



# 2-BEDROOM

TYPE D



INTERNAL LIVING AREA	1143.88 SQ. FT
OUTDOOR LIVING AREA	237.88 SQ. FT
<b>TOTAL LIVING AREA</b>	<b>1381.76 SQ. FT</b>

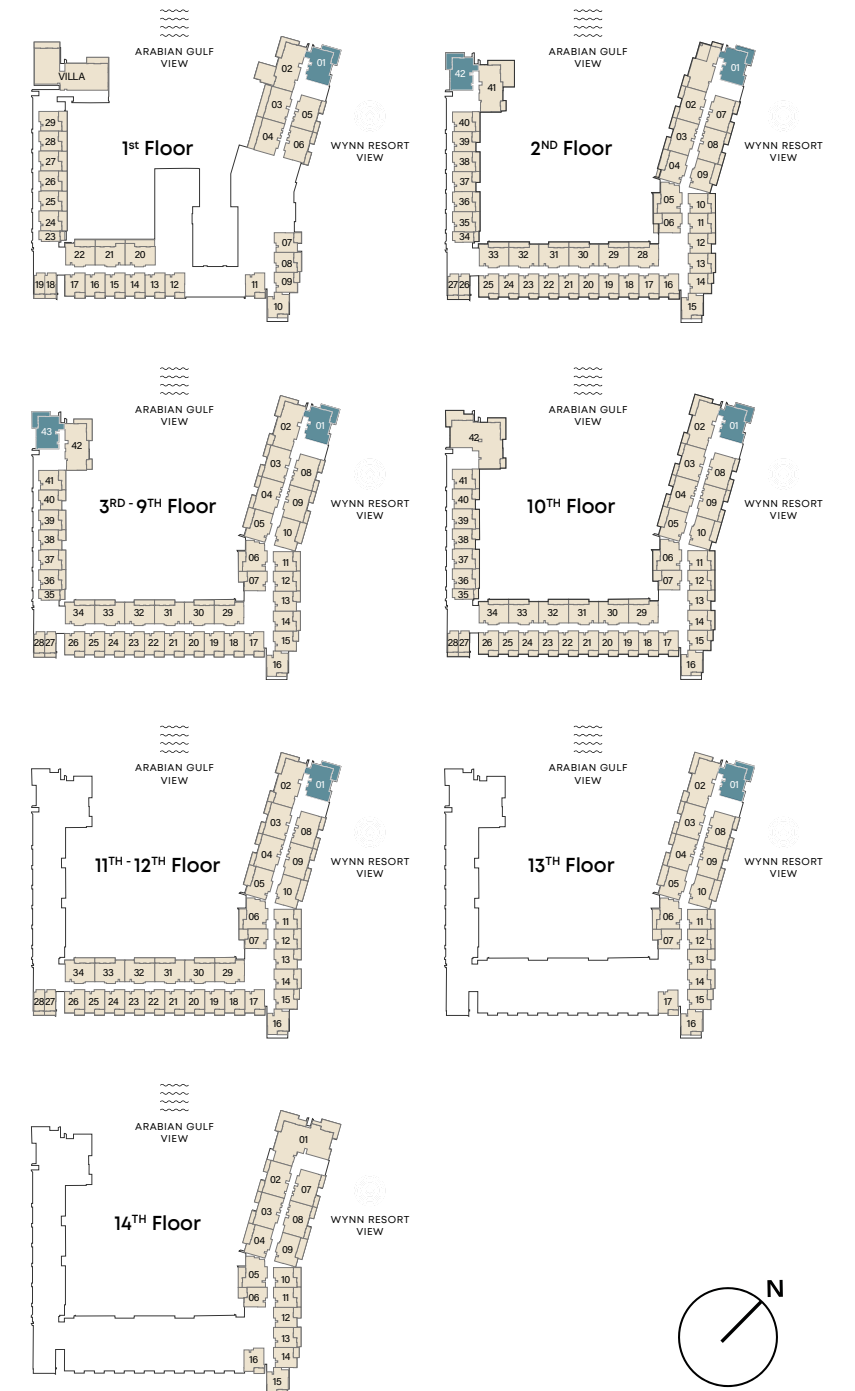



# 3-BEDROOM

## TYPE A



INTERNAL LIVING AREA	1549.57 SQ. FT
OUTDOOR LIVING AREA	356.93 SQ. FT
<b>TOTAL LIVING AREA</b>	<b>1906.53 SQ. FT</b>

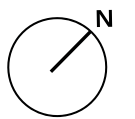
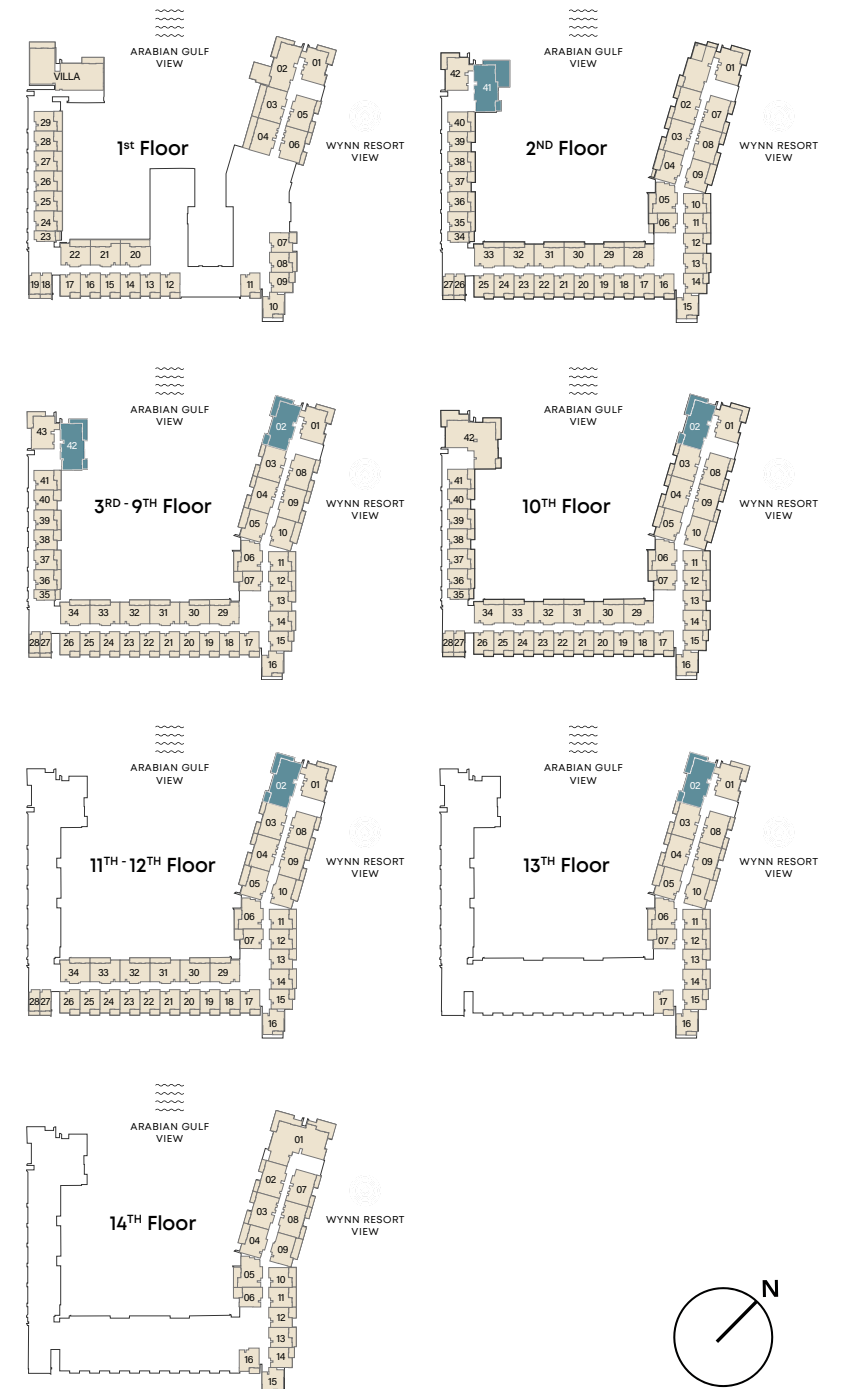



# 3-BEDROOM

## DUPLEX

INTERNAL LIVING AREA	2821.22 SQ. FT
OUTDOOR LIVING AREA	957.34 SQ. FT
<b>TOTAL LIVING AREA</b>	<b>3778.56 SQ. FT</b>



LOWER LEVEL

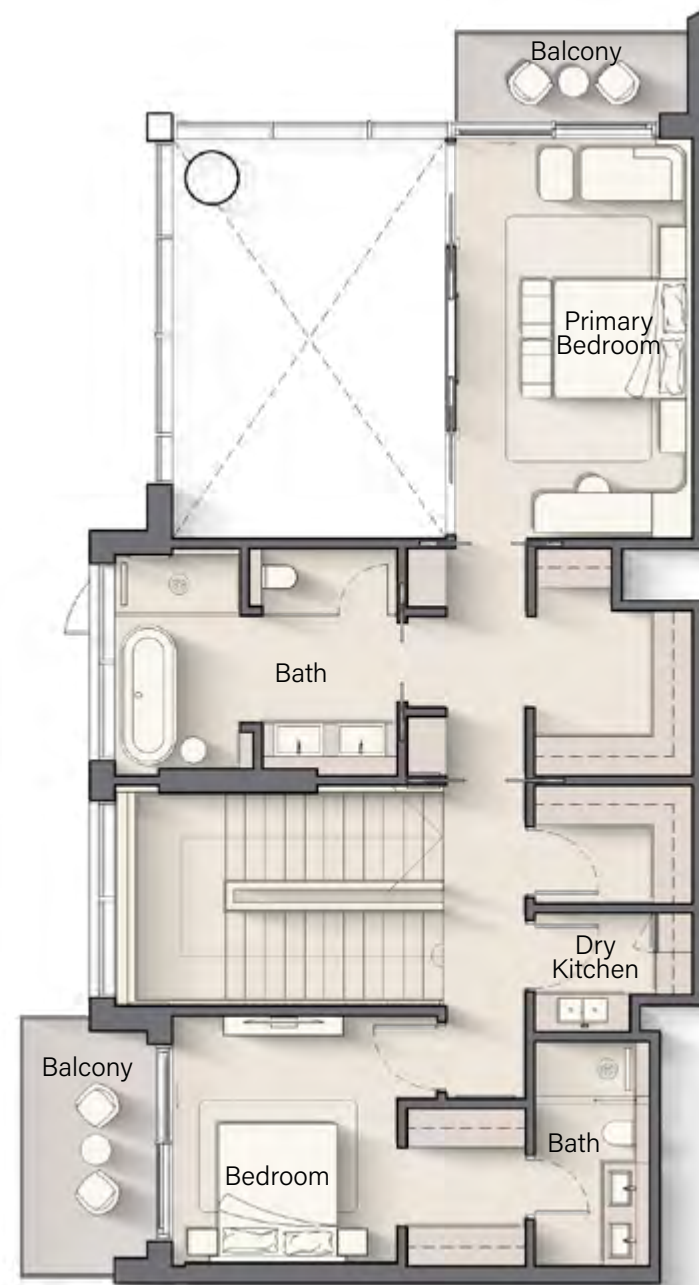

UPPER LEVEL

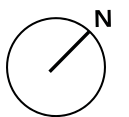
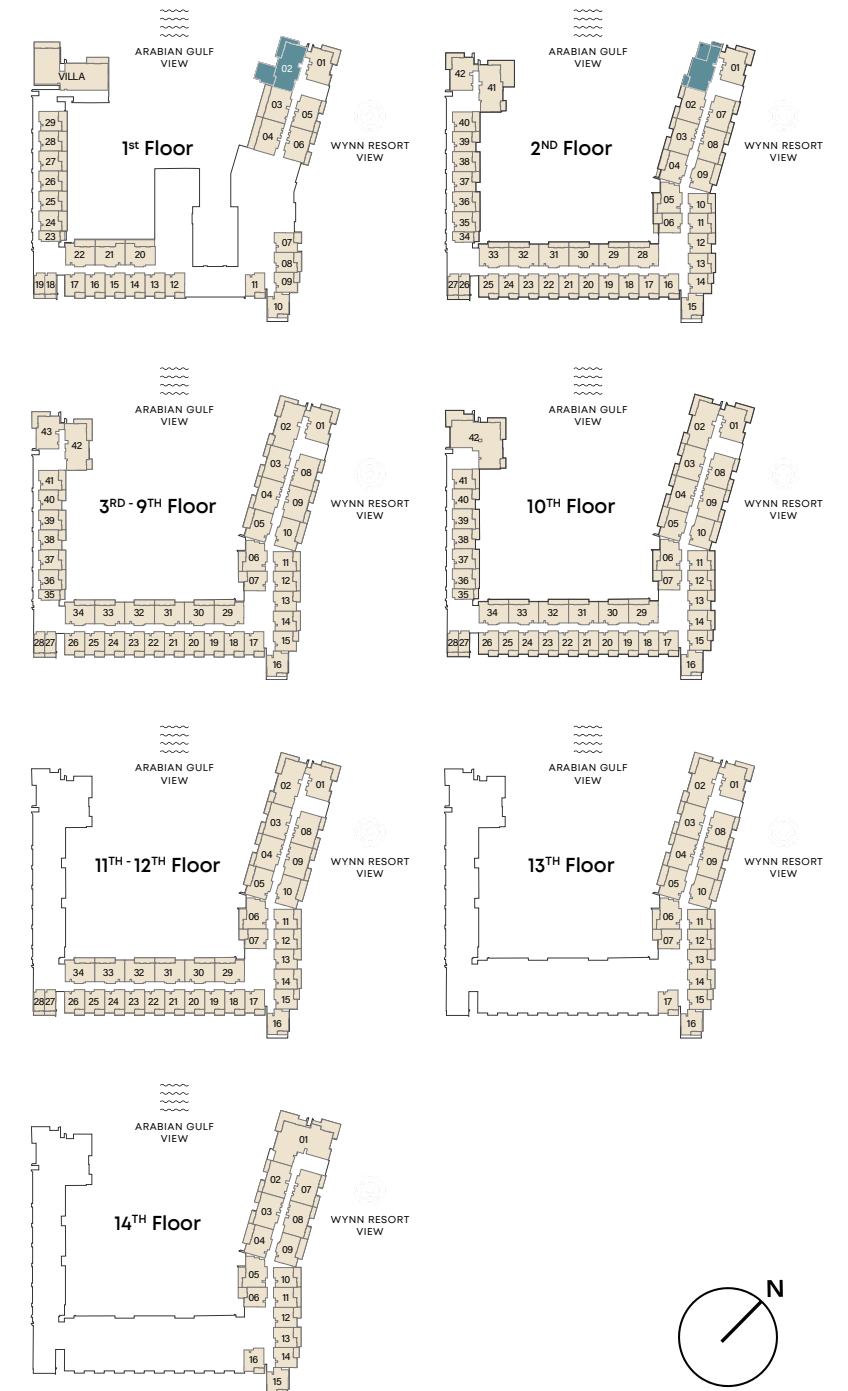



# PENTHOUSE

TYPE A



INTERNAL LIVING AREA	2771.81 SQ. FT
OUTDOOR LIVING AREA	778.55 SQ. FT
<b>TOTAL LIVING AREA</b>	<b>3550.37 SQ. FT</b>

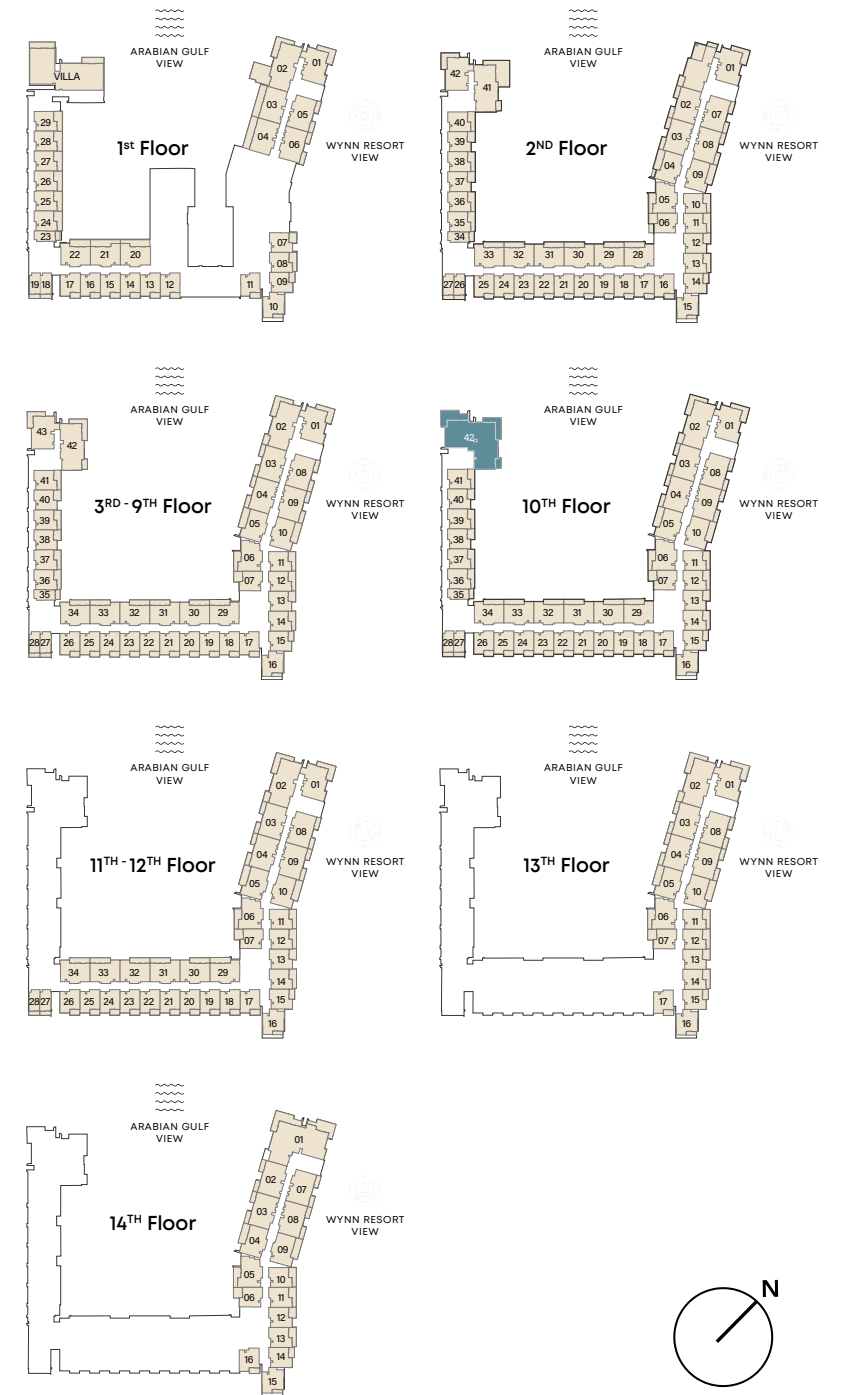



# PENTHOUSE

TYPE B



INTERNAL LIVING AREA	2648.57 SQ. FT
OUTDOOR LIVING AREA	810.52 SQ. FT
<b>TOTAL LIVING AREA</b>	<b>3459.09 SQ. FT</b>

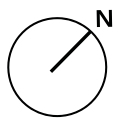
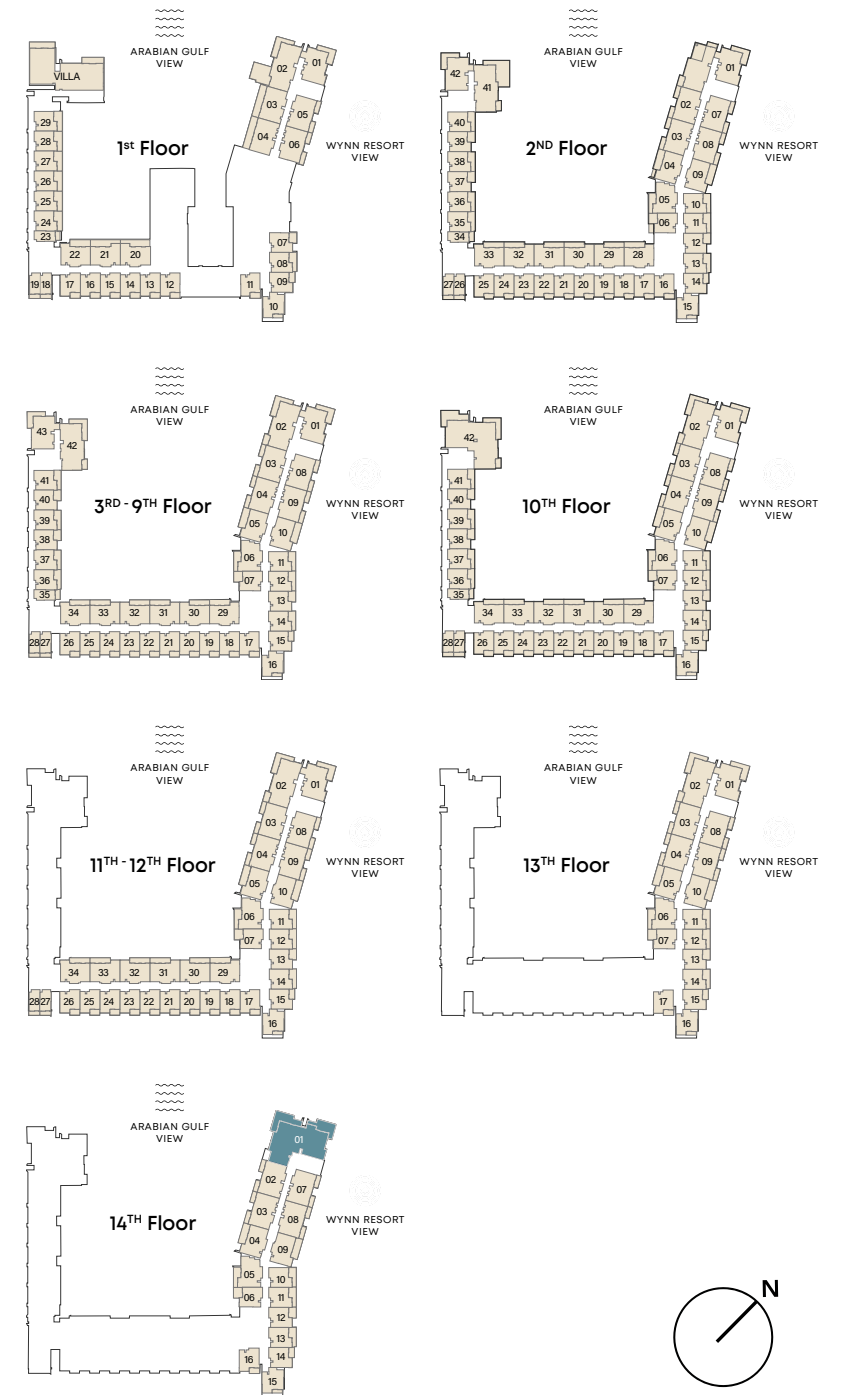



# THE VILLA

B + G + 1

LOWER LEVEL

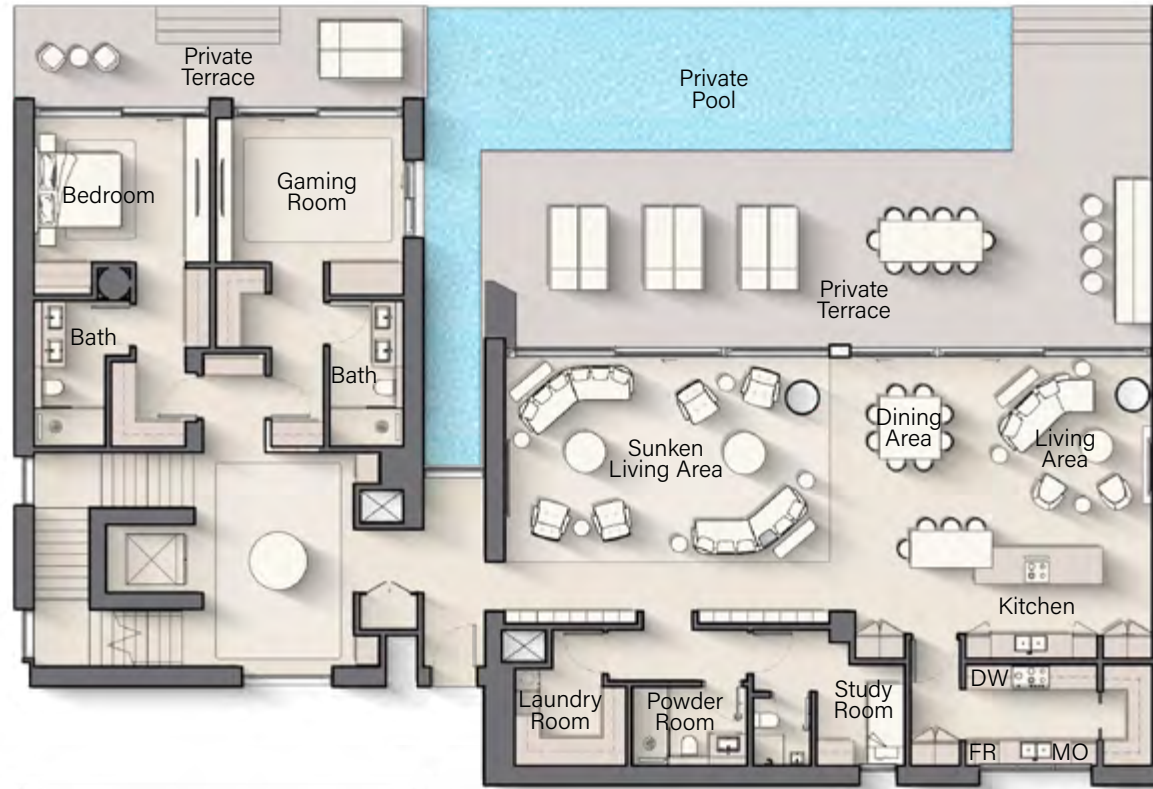

UPPER LEVEL

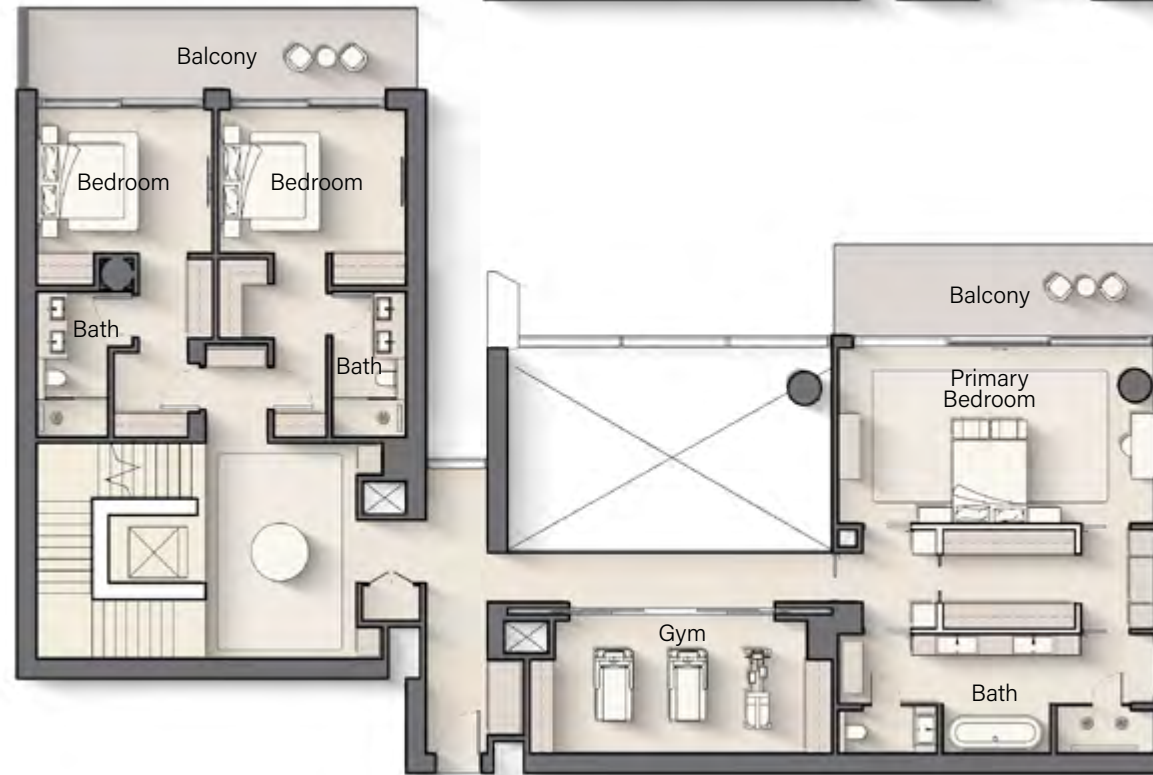

INTERNAL LIVING AREA	6392.15 SQ. FT
OUTDOOR LIVING AREA	2281.63 SQ. FT
<b>TOTAL LIVING AREA</b>	<b>8673.77 SQ. FT</b>

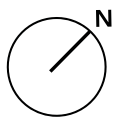
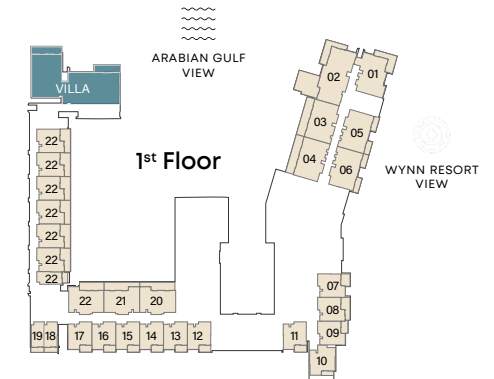
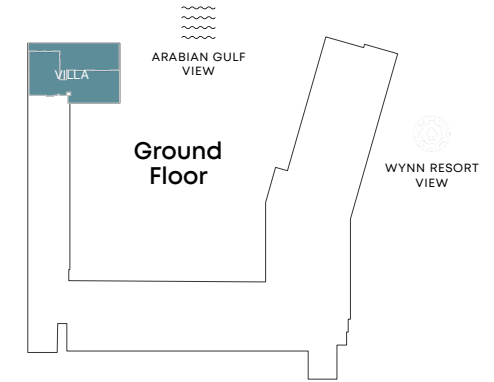



# PAYMENT PLAN

20%

AT THE TIME OF BOOKING  
+ AED 3,000 RERA  
REGISTRATION FEE

10%

90 DAYS AFTER THE  
RESERVATION DATE

10%

180 DAYS AFTER THE  
RESERVATION DATE

5%

ON COMPLETION OF  
20% CONSTRUCTION  
OF THE PROJECT

5%

ON COMPLETION OF  
30% CONSTRUCTION  
OF THE PROJECT

5%

ON COMPLETION OF  
40% CONSTRUCTION  
OF THE PROJECT

5%

ON COMPLETION OF  
50% CONSTRUCTION  
OF THE PROJECT

40%

ON COMPLETION\*

\* plus 4% upon completion and this amount is earmarked specifically  
to cover expenses related to the title deed registration process



# PROJECT INTERACTIVE APP

To navigate the project interactive web page of Playa Del Sol, click **HERE** or scan the QR code:



SCAN THE QR CODE







800 8288  
info@ellingtongroup.com

ELLINGTONPROPERTIES.AE

The renderings and visualizations contained in this brochure are provided for illustrative and marketing purposes. While the information provided is believed to be accurate and reliable at the time of printing, only the information contained in the final Sales and Purchase Agreement will have any legal effect.